

VARI®

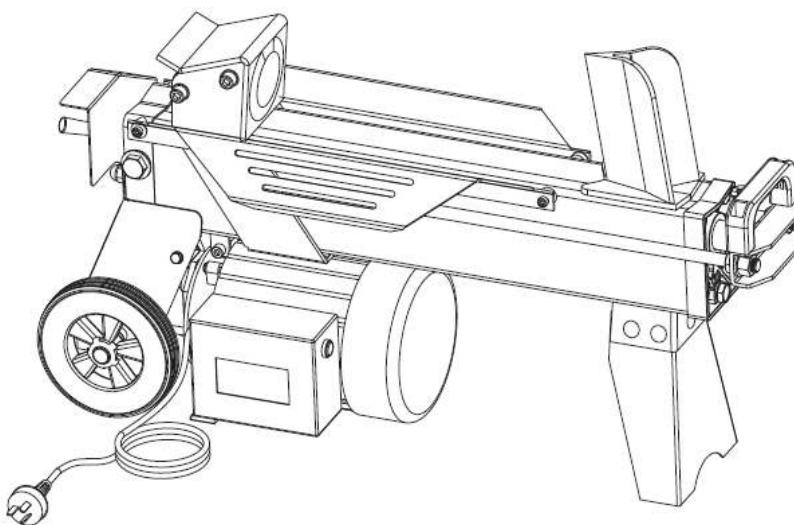

FOR YOUR SAFETY

**READ AND UNDERSTAND THE ENTIRE MANUAL
BEFORE OPERATING THE MACHINE**

MODEL: VARI 4 TON SUPER FORCE
SERIAL NUMBER:

Both model and serial number may be found on the main label.
You should record both of them in a safe place for future use.

Save This Manual for Future Reference



HORIZONTAL LOG SPLITTER
Instructions for use (Original instructions for use) 2010

SAFETY WARNINGS & CAUTIONS

SAFETY WARNINGS & INSTRUCTIONS

SYMBOL AFFIXED TO THE MACHINE

- **UNDERSTAND YOUR LOG SPLITTER**

Read and understand the owner's manual and labels affixed to the log splitter. Learn its application and limitations as well as the specific potential hazards peculiar to it.



- **DRUGS, ALCOHOL AND MEDICATION**

Do not operate the log splitter while under the influence of drugs, alcohol or any medication which could affect your ability to use it properly.

- **AVOID DANGEROUS CONDITIONS**

Put the log splitter on a 60 – 75 cm high, stable, flat and level work bench where there is plenty of room for handling and help the operator stay alert. Bolt the log splitter to the work surface if it tends to slip, walk or slide.

Keep your work area clean and well lighted. Cluttered areas invite injuries.

Do not use the log splitter in wet or damp areas or expose it to rain.

Do not use it in areas where fumes from paint, solvents or flammable liquids pose a potential hazard.

- **INSPECT YOUR LOG SPLITTER**

Check your log splitter before turning it on. Keep guards in place and in working order. Form a habit of checking to see that keys and adjusting wrenches are removed from tool area before turning it on. Replace damaged, missing or failed parts before using it.



- **DRESS PROPERLY**

Do not wear loose clothing, gloves, neckties or jewellery (rings, wrist watches). They can be caught in moving parts. Protective electrically non-conductive gloves and non-skid footwear are recommended when working. Wear protective hair covering to contain long hair, preventing it from get caught in machinery.



- **PROTECT YOUR EYES AND FACE**

Any log splitter may throw foreign objects into the eyes. This can cause permanent eye damage. Always wear safety goggles. Everyday eyeglasses have only impact resistant lenses. They are not safety glasses.

Do not put the log splitter on the ground for operations. This is awkward operating position in which the operator has to bring his face close to the machine and thus risks being struck by wood chips or debris.



• EXTENSION CORDS

Improper use of extension cords may cause inefficient operation of the log splitter, which can result in overheating. Be sure the extension cord is not longer than 10 m and its section is not less than 2.5 mm² to allow sufficient current flow to the motor.

Avoid use of free and inadequately insulated connections. Connections must be made with protected material suitable for outdoor use.

• AVOID ELECTRICAL SHOCK

Check that the electric circuit is adequately protected and that it corresponds with the power, voltage and frequency of the motor. Check that there is a ground connection and a regulation differential switch upstream.

Ground the log splitter. Prevent body contact with grounded surfaces: pipes, radiators, ranges and refrigerator enclosures.

Never open the pushbutton box on the motor. Should this be necessary, contact a qualified electrician.

Make sure your fingers do not touch the plug's metal prongs when plugging or unplugging the log splitter.

• KEEP VISITORS AND CHILDREN AWAY

The log splitter must be always operated by one person only. Other people should keep a safe distance from the work area, especially when the log splitter is under operation. Never use other people to help you with freeing a jammed log.

• INSPECT YOUR LOG

Make sure there are no nails or foreign objects in logs to be split. The ends of the logs must be cut square. Branches must be cut off the trunk.

• DON'T OVERREACH

The floor must not be slippery.

Keep proper footing and balance at all times.

Never stand on the log splitter. Serious injury could occur if the tool is tipped or if the cutting tool is unintentionally contacted. Do not store anything above or near the log splitter where anyone might stand on the tool to reach them.

• AVOID INJURY FROM UNEXPECTED ACCIDENT

Always pay full attention to the movement of the log pusher.

Do not attempt to load the log on until the log pusher has stopped.

Keep hands out of the way of all moving parts.

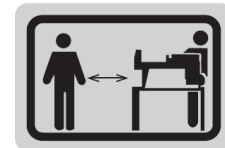

- **PROTECT YOUR HANDS**

Keep your hands away from splits and cracks which open in the log. They may close suddenly and crush or amputate your hands.

Do not remove jammed logs with your hands.

- **DON'T FORCE TOOL**

It will do a better and safer job at its design rate. Never try to split logs larger than those indicated in the specifications table. This could be dangerous and may damage the machine.

Don't use log splitter for a purpose for which it was not intended.

- **NEVER LEAVE TOOL RUNNING UNATTENDED**

Don't leave the tool until it has come to a complete stop.

- **DISCONNECT POWER**

Unplug when not in use, before making adjustments, changing parts, cleaning or working on the log splitter. Consult technical manual before servicing.

- **PROTECT THE ENVIRONMENT**

Take used oil to an authorized collection point or follow the stipulations in the country where the log splitter is used. Do not discharge into drains, soil or water.

- **MAINTAIN YOUR LOG SPLITTER WITH CARE**

Keep the log splitter clean for best and safest performance.

- **MAKE THE WORKSHOP CHILDPROOF**

Lock the shop. Disconnect master switches. Store the log splitter away from children and others not qualified to use it.



TABLE OF CONTENTS

SAFETY WARNINGS & CAUTIONS	2
APPLICATION CONDITIONS	5
SPECIFICATIONS.....	5
ELECTRICAL REQUIREMENTS.....	5
SET UP AND PREPARATION FOR OPERATION.....	6
WIRING DIAGRAM, PLUMBING DIAGRAM	7
LOG SPLITTER OPERATION.....	8
FREEING A JAMMED LOG.....	9
REPLACING HYDRAULIC OIL	10
SHARPENING WEDGE	10
TROUBLESHOOTING	11
PART LIST	12
DISPOSAL OF PACKAGING AND MACHINE AFTER THE END OF SERVICE LIFE	14
INSTRUCTIONS FOR ORDERING SPARE PARTS.....	14
ADDRESS OF THE MANUFACTURER	15
ADDRESS OF THE IMPORTER AND DISTRIBUTOR	15

APPLICATION CONDITIONS

This log splitter is a home use model. It is designed for operating under ambient temperatures between +5 °C and +40 °C and for installation at altitudes not more than 1000 m above M. S. L. The surround humidity should be less than 50 % at 40 °C. It can be stored or transported under ambient temperatures between -25 °C and +55 °C.

SPECIFICATIONS

Model	WS4T-37		
Trade Name	VARI 4 TON SUPER FORCE		
Motor	230 V ~ 50 Hz 1500 W IP54		
Log Size Capacity	Diameter*	5 – 25 cm	
	Length	37 cm	
Splitting Force	4 t		
Hydraulic Pressure	16 MPa		
Hydraulic Oil Capacity	2,4 l		
Overall Size	Length	780 mm	
	Width	270 mm	
	Height	510 mm	
Weight	40 kg		

* The diameter of the log is indicative – a small log can be difficult to split when it has knobs or a particularly tough fibre. On the other hand, it may not be difficult to split logs with regular fibres even if its diameter exceeds the max. figure indicated above.

ELECTRICAL REQUIREMENTS

Connect the main leads to a standard 230 V \pm 10 % (50 Hz \pm 1 Hz) electrical supply which has protection devices of under-voltage, over-voltage, over-current as well as a residual current device (RCD) which maximum residual current is rated at 0.03 A.

SET UP AND PREPARATION FOR OPERATION

1. Bolt the Support Leg to the Log Splitter, lift the Log Splitter by the handles at both ends and place it on a 60 – 75 cm high, stable, flat and level work surface.
2. Familiarize yourself with the controls and features of this log splitter in the illustrations.

1. Log Pusher
2. Work Table
3. Wedge
4. Lift Handle
5. Support Leg
6. Log Retaining Plates
7. Switch
8. Motor
9. Pushbutton box
10. Wheel for minor moving
ONLY
11. Hydraulic Control Lever
12. Control Lever Guard
13. Bleed Screw
14. Oil Drain Bolt with Dipstick

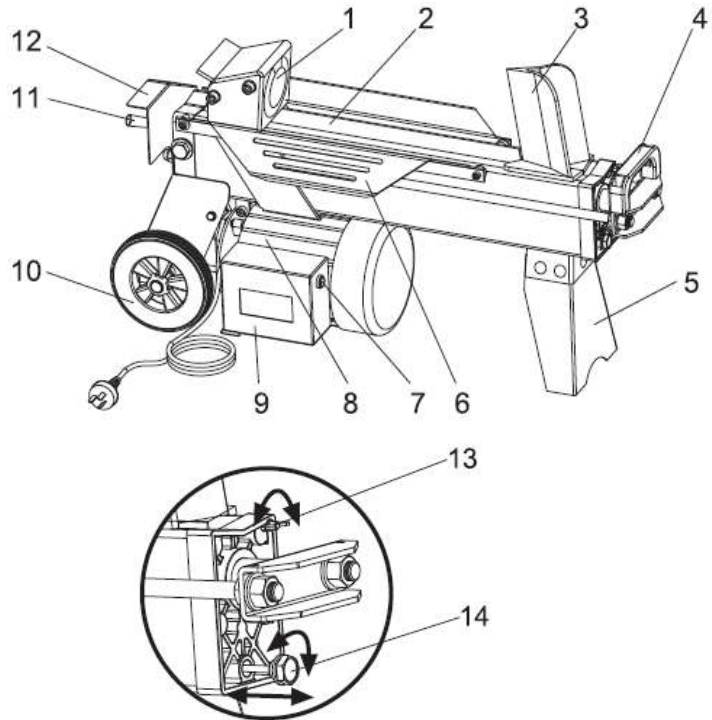

Before operating the log splitter, the Bleed Screw should be loosened by some rotations until air can go in and out of the oil tank smoothly.

Airflow thru the Bleed Screw hole should be detectable during the log splitter is under operations.

Before moving the log splitter, make sure the Bleed Screw is tightened to avoid oil leaking from this point.



FAILING TO LOOSEN THE BLEED SCREW WILL KEEP THE SEALED AIR IN HYDRAULIC SYSTEM BEING COMPRESSED AFTER BEING DECOMPRESSED. SUCH CONTINUOUS AIR COMPRESSION AND DECOMPRESSION WILL BLOW OUT THE SEALS OF THE HYDRAULIC SYSTEM AND CAUSE PERMANENT DAMAGE TO THE LOG SPLITTER.

15. Max. Pressure Limiting Screw



DO NOT ADJUST THE MAX. PRESSURE LIMITING SCREW!

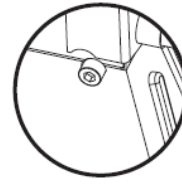

Max. pressure was set before the log splitter left the factory and the max. pressure limiting screw is sealed with glue to ensure the log splitter works under pressure not more than 4 tons. The setting was done by qualified mechanic with professional instruments.

Unauthorized resetting will cause the hydraulic pump fail to output enough splitting pressure or **RESULT IN SERIOUS INJURY AS WELL AS DAMAGE TO THE MACHINE.**

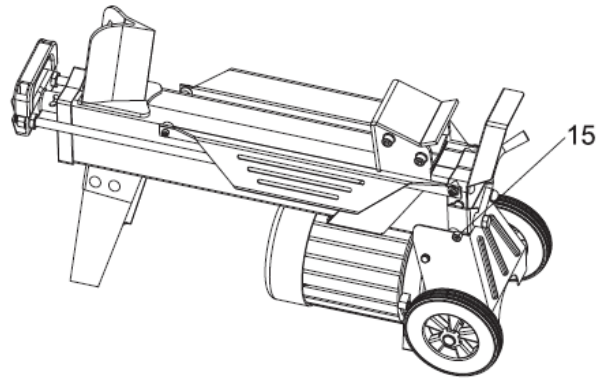

WIRING DIAGRAM

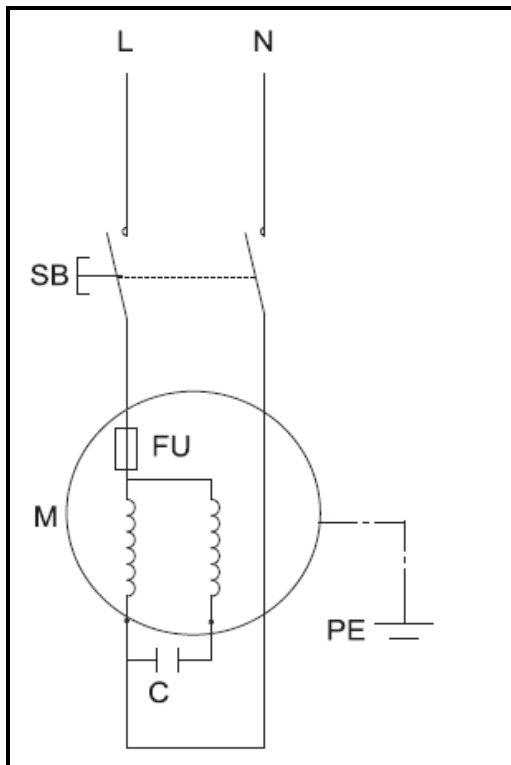

PLUMBING DIAGRAM

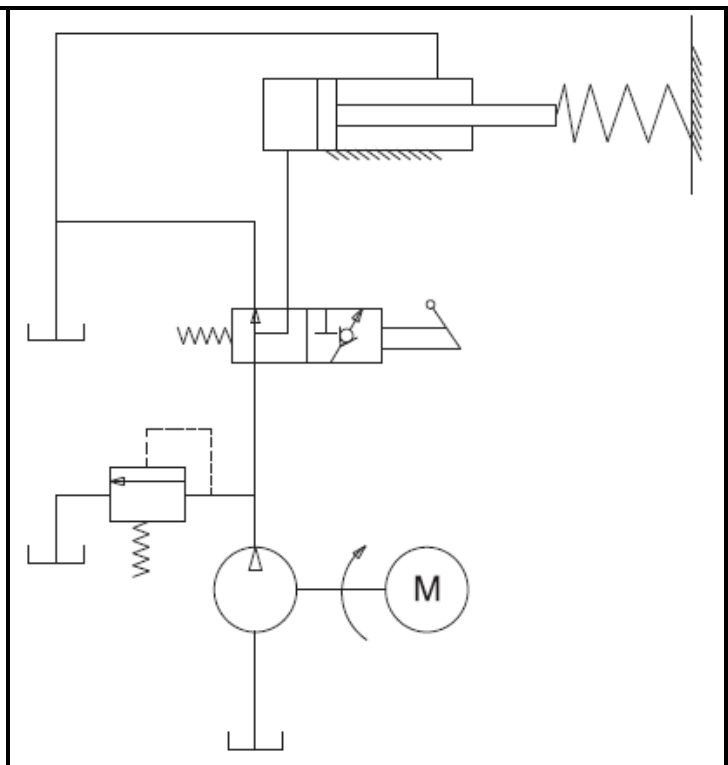

LOG SPLITTER OPERATION

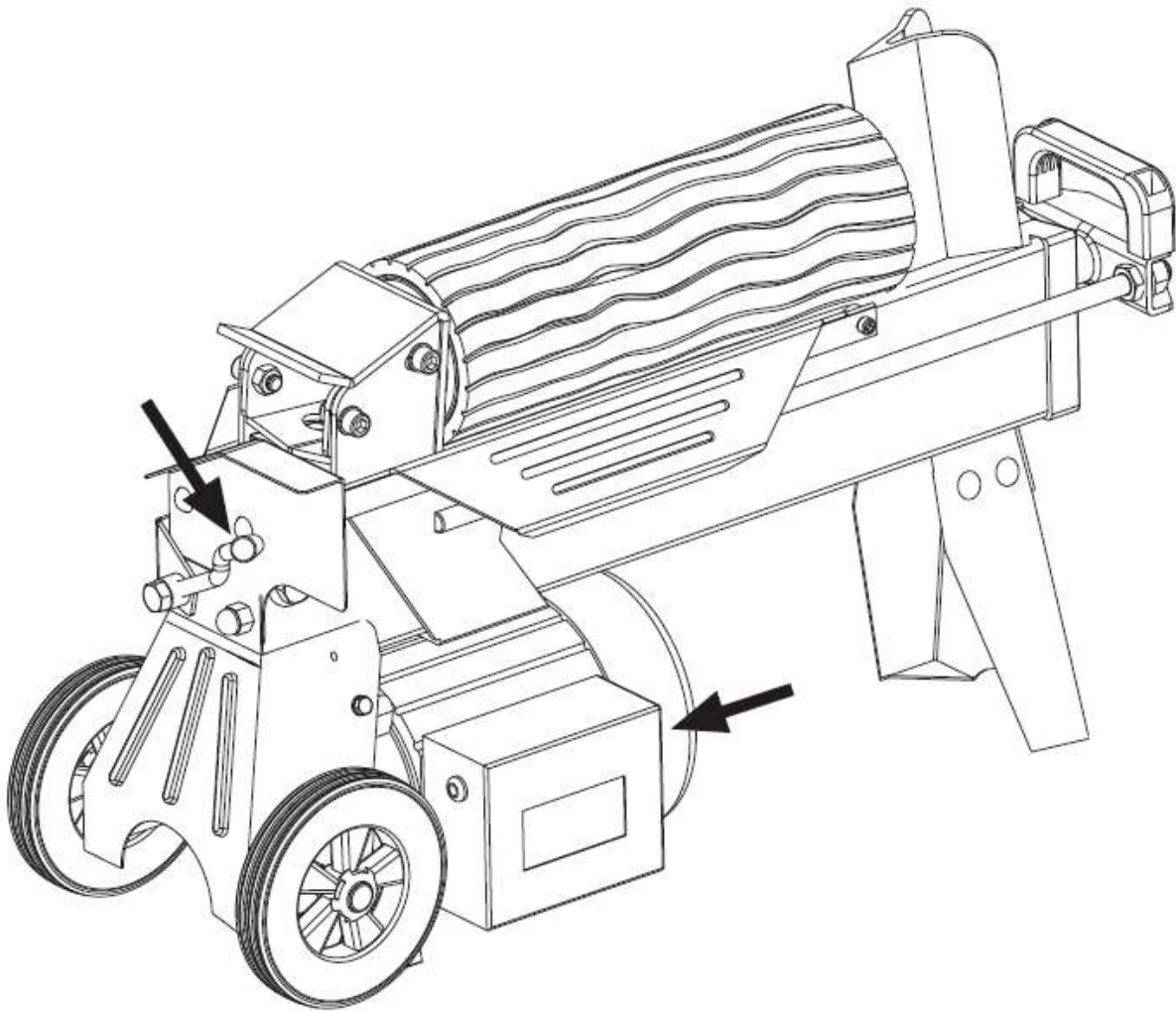

This log splitter is equipped with “ZHB” control system that requires to be operated by both hands of the user – left hand controls the hydraulic control lever while right hand controls the pushbutton switch. The log splitter will freeze upon absence of either hand. Only after both hands release the controls, the log pusher starts to return backward to the starting position.

Trigger type lockout device is adopted to avoid accidental Hydraulic Control Lever pushdown. To operate the Hydraulic Control Lever, draw the Trigger backward with the index finger before you push the Hydraulic Control Lever forward.



Never force the log splitter for more than 5 seconds by keeping pressure on it to split excessively hard wood.

After this time interval, the oil under pressure will be overheated and the machine could be damaged. For such extremely hard log, rotate it by 90° to see whether it can be split in a different direction. In any case, if you are not able to split the log, this means that its hardness exceeds the capacity of the machine and thus that the log should be discarded to protect the log splitter.

Always set logs firmly on the log retaining plates and worktable. Make sure logs will not twist, rock or slip while being split. Do not force the blade by splitting the log on the upper part. This will break the blade or damage the machine.

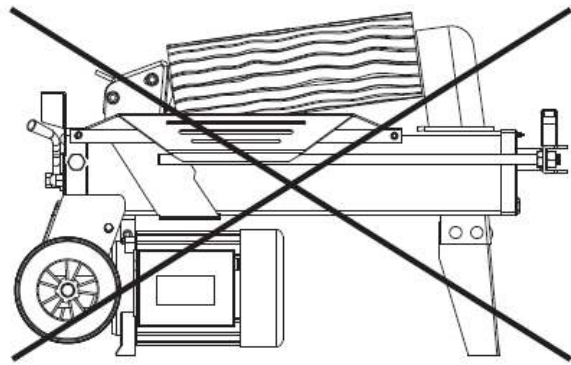

Break log in the direction of its growing grain. Do not place log across the log splitter for splitting. It may be dangerous any may seriously damage the machine. Do not attempt to split 2 pieces of logs at the same time. One of them may fly up and hit you.

FREEING A JAMMED LOG

- Release both controls.
- After the log pusher moves back and completely stops at its starting position, insert a wedge wood under the jammed log.
- Start the log splitter to push the wedge wood to go completely under the jammed one.
- Repeat above procedure with sharper slope wedge woods until the log is completely freed.

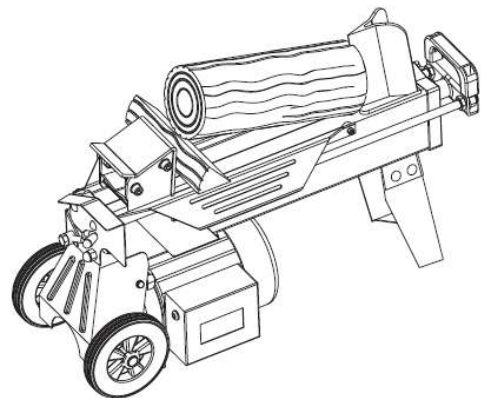

Do not try to knock the jammed log off. Knocking about will damage the machine or may launch the log and cause accident.

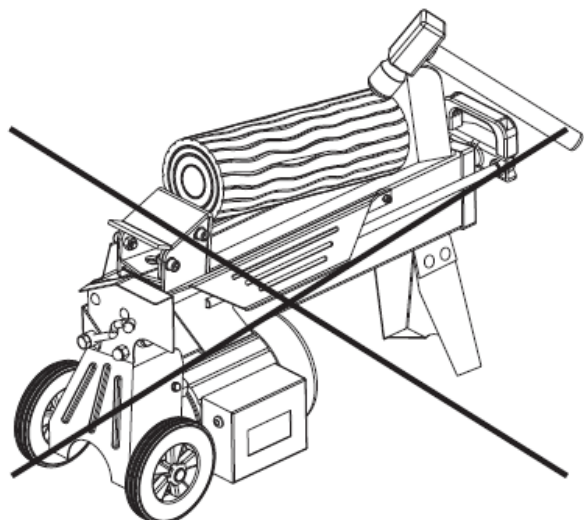

REPLACING HYDRAULIC OIL

Replace the hydraulic oil in the log splitter after every 150 hours of use. Take following steps to replace it:

- Make sure all moving parts are stopped and the log splitter is unplugged.
- Unscrew Oil Drain Bolt with Dipstick to remove it.
- Turn the log splitter on the Support Leg side over a 4 litres capacity container to drain the hydraulic oil off.
- Turn the log splitter on the motor side.
- Refill fresh hydraulic oil at the volume as per the hydraulic oil capacity of a particular model indicated in the above specifications table.
- Clean the surface of Dipstick on the Oil Drain Bolt and put it back into the oil tank while keep the log splitter vertically.
- Make sure the level of the refilled oil is just between 2 grooves around the Dipstick.
- Clean the Oil Drain Bolt before thread them back. Make sure they are tightened to avoid leakage before placing the log splitter horizontally.

Periodically check oil level to ensure it is between 2 grooves around the Dipstick. Upon lower oil level, oil refilling is required.

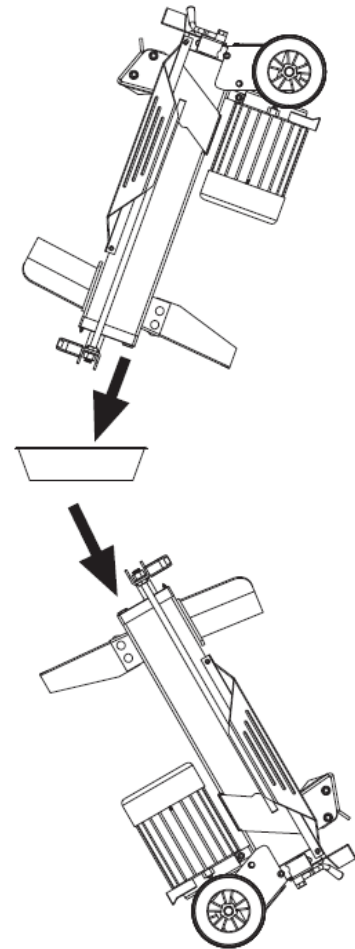

Following hydraulic oils or equivalent are recommended for the log splitter's hydraulic transmission system:

SHELL Tellus 22

MOBIL DTE 11

ARAL Vitam GF 22

BP Energol HLP-HM 22

SHARPENING WEDGE

After using the log splitter for some time, sharpen the wedge of the log splitter using a fine-toothed file and smooth any burrs or crushed area along the cutting edge.

TROUBLESHOOTING

PROBLEM	PROBABLE CAUSE	REMEDY SUGGESTED
Fails to split logs.	Log is improperly positioned.	Refer to “Log Splitter Operation” section for perfect log loading.
	The size or hardness of the log exceeds the capacity of the machine.	Reduce the log sizes before splitting it on the log splitter.
	Wedge cutting edge is blunt.	Refer to “Sharpening Wedge” section to sharpen the cutting edge.
	Oil leaks.	Locate leak(s) and contact the dealer.
	Unauthorized adjustment was made on Max. Pressure Limiting Screw. Lower max. pressure rating was set.	Contact the dealer.
The log pusher moves jerkily, taking unfamiliar noise or vibrating a lot.	Lack of hydraulic oil and excessive air in the hydraulic system.	Check oil level for possible oil refilling. Contact the dealer.
Oil leaks around cylinder ram or from other points.	Air sealed in hydraulic system while operating.	Loosen Bleed Screw by 3-4 rotations before operating the log splitter.
	Bleed Screw is not tightened before moving the log splitter.	Tighten the Bleed Screw up before moving the log splitter.
	Oil Drain Bolt with Dipstick is not tight.	Tighten the Oil Drain Bolt with Dipstick.
	Hydraulic Control Valve Assembly and / or seal(s) worn.	Contact the dealer.

PART LIST

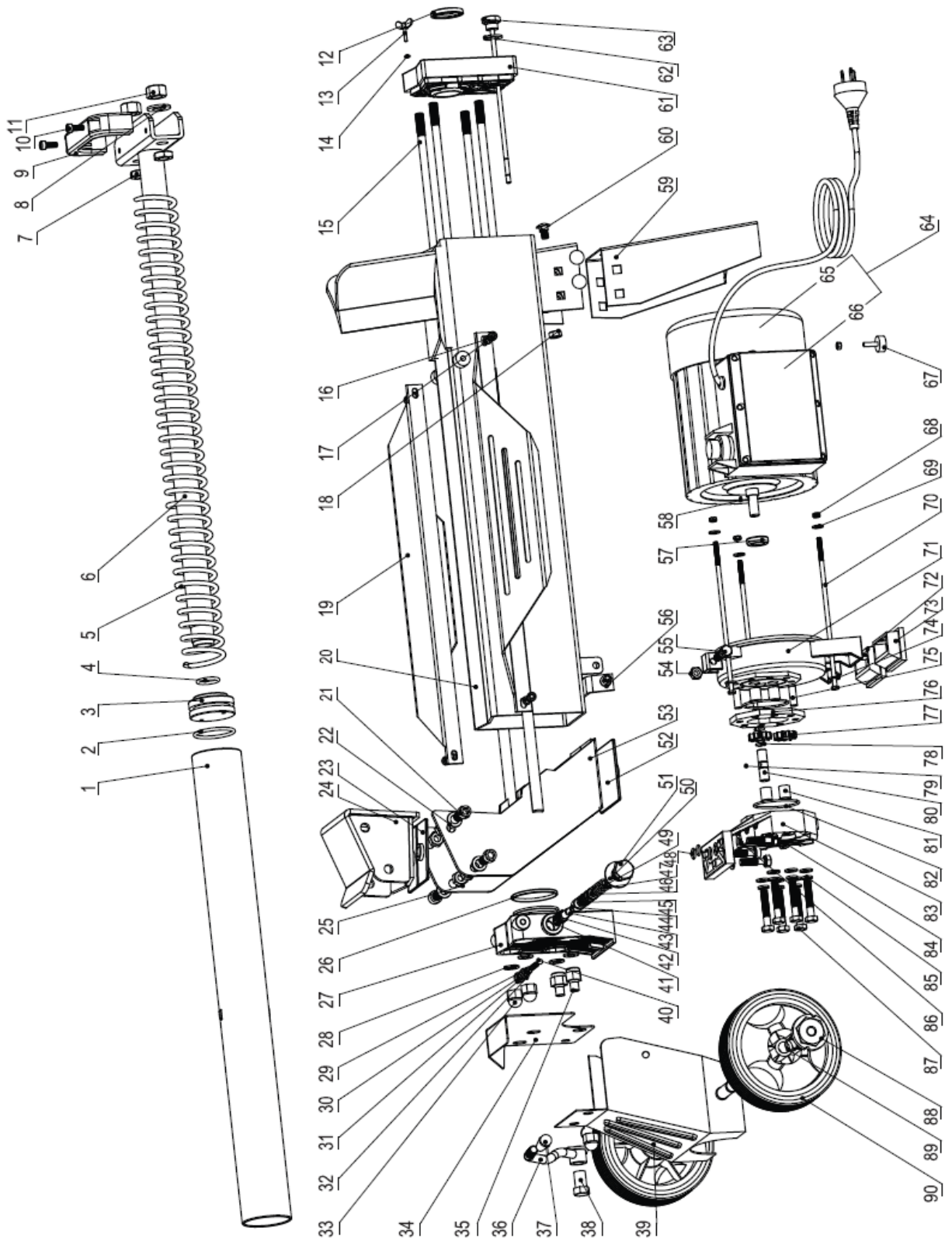

1	2	3	4	5	6	7	8	9	10	11
12	13	14	15	16	17	18	19	20	21	22
23	24	25	26	27	28	29	30	31	32	33
34	35	36	37	38	39	40	41	42	43	44
45	46	47	48	49	50	51	52	53	54	55
56	57	58	59	60	61	62	63	64	65	66
67	68	69	70	71	72	73	74	75	76	77
78	79	80	81	82	83	84	85	86	87	88
89	90									

Pos.	Part Name	Ord. No.	Pos.	Part Name	Ord. No.
1	Cylinder	201600	46	O-ring	-
2	Piston O-ring	201601	47	Sliding Sleeve Spring	201623
3	Piston	201602	48	O-ring 10.6x2.65	-
4	O-ring	201603	49	Sliding Sleeve	201624
5	Spring	201604	50	Washer	-
6	Piston Rod Weldment	201605	51	Valve Plug	201625
7	Nut	-	52	Lower Plastic Insert	201626
8	Washer	-	53	Drawing Weldment	201627
9	Moving Handle	201606	54	Loose Nut	-
10	Hex. Bolt	-	55	Hex. Bolt	-
11	Nut, M14	-	56	Washer	-
12	Plastic Seal	201607	57	Motor Shaft Seal	201628
13	Wing Screw / Bleed Screw	-	58	Steel Ball, 2.5	-
14	O-ring 7x1.9G	-	59	Support Leg	201629
15	Long Stub	201608	60	Bolt	-
16	Hex. Bolt	-	61	Cylinder Cover - Right	201630
17	Spring washer	-	62	Dipstick Gasket	201631
18	Nut	-	63	Dipstick	201632
19	Support Plate	201609	64	Motor with switch	201633
20	Tube Frame / Oil Tank	201610	65	Motor	201634
21	Hex. Bolt	-	66	Switch box	201635
22	Washer	-	67	Bolt	-
23	Upper Plastic Insert	201611	68	Nut	-
24	Log Pusher Weldment	201612	69	Spring Washer	-
25	Nut	-	70	Bolt	-
26	O-ring 55x3.1G	-	71	Motor Cover	201636
27	Cylinder Cover - Left	201613	72	Motor Support Shoe - Left	201637
28	Copper Gasket	-	73	Motor Support Shoe - Right	201638
29	Safety Valve Spring	201614	74	Washer	-
30	Screw	-	75	Pin	201639
31	Safety Valve Bolt	-	76	Gear Housing Plate	201640
32	O-ring	-	77	Gear	201641
33	Round Head Nut	-	78	Gear Shaft Snap Washer	201642
34	Lever Guard	201615	79	Pin	-
35	Nut	-	80	Gear Shaft	201643
36	Lever Weldment	201616	81	Sliding Bearing	-
37	Lever Head	201617	82	O-ring 46.2x1.8	-
38	Lever Nut	201618	83	Pump Cover	201644
39	Wheel Frame Plate Weldment	201619	84	Bolt	-
40	Steel Ball, 6	-	85	Spring washer	-
41	Circlip	-	86	Washer	-
42	Restore Valve Spring	201620	87	Bolt	-
43	Valve Rod	201621	88	Wheel Cover	201645
44	O-ring	-	89	Wheel Shaft Snap Ring	201646
45	Valve Sleeve	201622	90	Wheel	201647

DISPOSAL OF PACKAGING AND MACHINE AFTER THE END OF SERVICE LIFE

After unpacking the machine, you are obliged to provide for the disposal of packaging material with taking into account the use of secondary raw materials according to the legislation valid in your country and with respect to the decrees of local town or municipal authorities.

The following procedure is recommended for machine disposal after the end of its service life:

1. Dismount all parts from the machine that can still be used.
2. Dismount plastic machine parts and parts made of non-ferrous metals. The dismantled machine remainder and the dismantled parts are to be disposed according to the legislation valid in your country and with respect to the decrees of local town or municipal authorities.
3. Regarding waste from the electrical device, use the opportunity of **return buy-out** in the shop, where you purchased the device (**points 1 and 2 are not valid in this case**).
4. The machine is in accordance with the RoHS Directive (2002/95/EC, 2002/96/EC, 2003/108/EC).
5. The product is in accordance with the requirements of the above-mentioned EC Directive regarding the quantities of forbidden dangerous substances.



This pictograph means that the product was introduced on the market after 13th September 2005 and shall not be disposed to a waste container or a dustbin.

INSTRUCTIONS FOR ORDERING SPARE PARTS

The following data are to be used for an easier identification when ordering the spare parts:

1. Machine type, engine type, machine serial number and year of manufacture;
2. Ordering number given by manufacturer and its name in the part list;
3. Number of ordered pieces separately for each item;
4. Precise address, telephone number, fax number or e-mail address;
5. Should you be uncertain about the correct identification of the component, send the damaged component either to the nearest service shop or directly to the manufacturer;
6. All components should be ordered in the nearest service shop or at your dealer's.

In the case of any confusions concerning the spare parts or technical issues, the VARI a.s. commercial, customer-service or technical departments are prepared to answer all your inquiries.

ADDRESS OF THE MANUFACTURER

TIYA International Co., Ltd., B12B Shenye Centre, 9 Shandong Road, Qingdao,
P.R.China

ADDRESS OF THE IMPORTER AND DISTRIBUTOR

VARI,a.s.	phone:	(+420) 325 607 111
Opolanska 350	fax:	(+420) 325 607 264
Libice nad Cidlinou		(+420) 325 637 550
CZECH REPUBLIC	e-mail:	vari@vari.cz
289 07	internet:	http://www.vari.cz/

EC DECLARATION OF CONFORMITY

according to Act No. 22/1997 Gaz.
(as amended)

1 Importer:

VARI,a.s. , Opolanská 350, 289 07 Libice nad Cidlinou, Czech Republic

Registration No.: 00660574 , V.A.T. No.: CZ00660574 . Registered in the Company Register at Municipal Court of Prague on 29th January 1991 Section B, Insert 499.

issue the following statement at their own responsibility:

2 Description of the electrical device:

Trade mark	Name	Type	Serial nos.
VARI	Log splitter	VARI 4 TON SUPER FORCE	000001-999999
Input	1500W/230V	Weight	40 kg
Pressure force	4 tons	Log length	370 mm

The VARI 4 TON SUPER FORCE log splitter is intended for simple splitting of wood logs. A ram pushes the log on a sharp wedge which breaks the wood log. This log splitter is equipped with two wheels for easier handling with the machine before work begins. The machine drive is electro hydraulic.

3 Regulations according to which the conformity was assessed:

NV No. 17/2003 Gaz. (2006/95/EC), NV No. 616/2006 Gaz. (2004/108/EC), NV No. 176/2008 Gaz. (2006/42/EC)

(all Decrees of the Government /NV/ and directives as amended)

4 Authorized person which made the measurements:

TÜV Rheinland Group, 6F, Flat B, Fu Tai Plaza, 18 Hong Kong Middle Road, Qingdao 266071, P.R. China
Test reports : 17703106001, 17702532001

5 Authorized person which issued the certificates:

TÜV Rheinland Product Safety GmbH – Am Grauen Stein – D-51105 Cologne
Certificates : AN501731640001, AM501731660001, AE501269140001, S50168116

6 Harmonised technical standards and technical specifications used:

EN60204-1:2006, EN609-1+A2:2009, EN55014-1:2006,
EN55014-2:1997+A1, EN61000-3-2:2006, EN61000-3-11:2000

7 Last two digits of the year when the product was marked with CE : 06

8 Technical documentation file No. in which the product's compliance with the regulations is assessed:

STD/007/2010

9 We declare that:

This machine, as defined with the above-mentioned data, complies with the basic requirements of the Government Decree (NV) and technical regulations and is safe under conditions of usual or by the manufacturer specified use. Furthermore precautions have been made to guarantee conformity of all products introduced on the market with the technical documentation and requirements of the technical regulations. The machine is safe under conditions of usual or specified use.

Place of issue of the declaration of conformity: Libice nad Cidlinou Date: 29.1.2010

Name, surname and function of the person authorized to sign this EC Declaration of Conformity:
Jiří BELINGER, Director General (CEO) and Chairman of the Board of Directors VARI,a.s.

Signature:



Stamp:

VARI® - Konstrukce
Opolanská 350
289 07 Libice nad Cidlinou
DIČ: CZ00660574

LETTER OF GUARANTEE**To be completed by importer**

Name of product **Log splitter**
 Model **VARI 4 TON SUPER FORCE**
 Serial number
 Engine serial number
 Warranty (months) **24**
 Output control

The above product was passed over to the purchaser without any defects including the appropriate commercial and technical documentation and accessories. The purchaser was duly informed about the principles of sound operation and technical maintenance of the product.

To be completed by seller

Name of purchaser
 Address of purchaser
 Purchaser's signature
 Place of sale
 Date of sale

Seller's stamp and signature

GUARANTEE CONDITIONS**Subject of warranty:**

Warranty relates to the basic product including accessories supplied by VARI a.s.

Warranty period:

Warranty period for the product and accessories supplied with the product is 24 months from the date of sale to the purchaser. Time from the enforcement of liability for defects to the date when the user was obliged to take over the thing after the end of repair is not included in the warranty period.

The seller is obliged to give the purchaser a receipt confirming the date of the right exercise and repair and the time of its duration. If the product is exchanged, the warranty period starts running again from the date on which the purchaser took over the new product. If it is a whole assembly to be replaced, the warranty period starts running for the given assembly again from the date of product take-over.

Scope of manufacturer's liability:

Importer bears responsibility for the product having properties usual for the kind of the product in question and specified parameters for the whole period of warranty. The importer does not answer for defects of the product resulting from current wear or from the product's use for purposes other than specified.

Warranty extinction:**Claim of warranty extincts if:**

- a) the product was not used and maintained as specified in the Operating manual, or it was damaged by any unauthorized operation by the user;
- b) the product was used in conditions or for purposes other than specified;
- c) the letter of guarantee for the product cannot be presented;
- d) data filled in the original product's documentation by the manufacturer, seller or service organization were intentionally falsified;
- e) a part of the product was replaced with a non-original component;
- f) the product was damaged or excessively worn due to improper maintenance;
- g) the product suffered an accident or was damaged by an Act of God;
- h) a modification was made to the product without manufacturer's consent;
- i) defects result from improper storage of the product;
- j) defects result from natural and common operating wear of the product;
- k) the product was connected to or operated with the equipment not approved by the manufacturer.

Complaints:

Complaints are applicable by purchasers at the seller's. When applying a complaint, the purchaser is obliged to submit a duly filled in letter of guarantee. Warranty repairs are carried out by sellers or by special service shops appointed by them.

Legislation:

Other purchaser/seller relations are ruled by relevant stipulations of the Civil Code No. 47/1992 Gaz., and/or Commercial Code No. 513/1991 Gaz. as amended.

<p>Warranty inspection 1 Date:Person in charge:.....</p> <p>Service shop stamp and signature</p>	<p>Warranty inspection 1 Machine model..... Serial No.:.....</p>
<p>Warranty inspection 2 Date:.....Person in charge:.....</p> <p>Service shop stamp and signature</p>	<p>Warranty inspection 2 Machine model..... Serial No.:.....</p>
<p>1st Warranty service Date of complaint delivery:..... Date of repair:..... Brief description of the defect..... Replaced parts (new warranty of ... months):..... Parts:..... Repair made by:</p> <p>Service shop stamp and signature</p>	<p>1st Warranty service Machine model..... Serial No.:..... Date:..... Repair made by:.. Stamp and signature.....</p>
<p>2nd Warranty service Date of complaint delivery:..... Date of repair:..... Brief description of the defect:..... Replaced parts (new warranty of ... months):..... Parts:..... Repair made by:</p> <p>Service shop stamp and signature</p>	<p>2nd Warranty service Machine model..... Serial No.:..... Date:..... Repair made by:..... Stamp and signature:.....</p>
<p>3rd Warranty service Date of complaint delivery:..... Date of repair:..... Brief description of the defect:..... Replaced parts (new warranty of ... months):</p> <p>Parts:..... Repair made by:</p> <p>Service shop stamp and signature</p>	<p>3rd Warranty service Machine model..... Serial No.:..... Date:..... Repair made by:..... Stamp and signature:.....</p>
<p>4th Warranty service Date of complaint delivery:..... Date of repair:..... Brief description of the defect:..... Replaced parts (new warranty of ... months):..... Parts:..... Repair made by:.....</p> <p>Service shop stamp and signature</p>	<p>4th Warranty service Machine model..... Serial No.:..... Date:..... Repair made by:..... Stamp and signature:.....</p>